

HUMIDITY SEPARATORS S25/S (PN 63)



DESCRIPTION

The S25 series centrifugal separators remove moisture from steam and compressed air pipelines. Steam and compressed air pass through the separator and, as a result of centrifugal forces, impacts and swirling effects, the particles with a heavier specific gravity, such as water and oil droplets, moisture in suspension, dirt and scale are separated from the fluid.

The condensate collected at the bottom of the separator must be automatically drained by a suitable steam or compressed air trap.

MAIN FEATURES

Several possibilities of installation.

No moving parts.

Maintenance-free design.

OPTIONS: Flanged condensate connection.

USE: Steam, compressed air and other gases.

AVAILABLE MODELS: S25/S – carbon steel.

SIZES: DN 15 to DN 200.

CONNECTIONS: Flanged EN 1092-1 PN 63.
Flanged ASME B16.5 Class 600 on request.
Socket weld (SW) ASME 16.11.

INSTALLATION: Always with the condensate discharge pointing downwards.
See IMI – Installation and maintenance instructions.



CE MARKING – GROUP 2 (PED – European Directive)	
PN 63	Category
DN 15 to 25	1 (CE marked)
DN 32 to 50	2 (CE marked)
DN 65 to 125	3 (CE marked)
DN 150 to 200	4 (CE marked)

BODY LIMITING CONDITIONS *	
FLANGED PN 63 / CLASS 600	
ALLOWABLE PRESSURE	RELATED TEMPERATURE
58 bar	100 °C
47 bar **	261 °C
43 bar	300 °C

* Rating according to EN 1092-1:2018.

** PMO – Max. operating pressure for saturated steam.
Minimum operating temperature: -10 °C.

Design code: AD-Merkblatt.

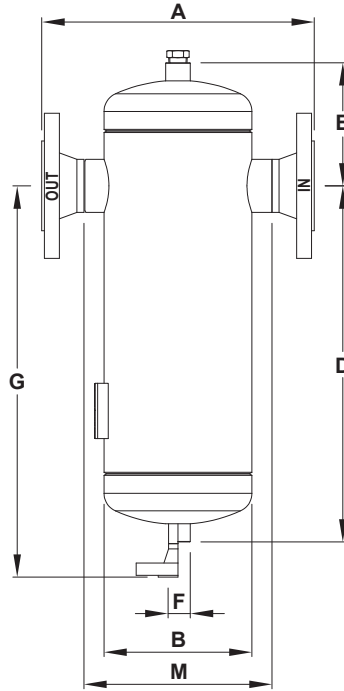

APPROXIMATE DIMENSIONS (mm) *

SIZE	A	B	D	E	F ***	G	VOLUME (L)	WEIGHT (kg)	M (SW)	WEIGHT (kg)
DN 15 **	245	114	230	125	1/2"	254	2	5,5	200	4,5
DN 20 **	245	114	222	133	1/2"	250	2,5	6,5	190	4,6
DN 25 **	265	114	254	136	1/2"	280	3	7,8	205	5,5
DN 32 **	295	140	330	145	1/2"	356	5	12,8	238	8,8
DN 40 **	295	140	368	147	1/2"	394	5,7	14,4	245	9,7
DN 50	340	168	415	170	1/2"	450	10,5	20,6	300	15,6
DN 65	410	219	433	197	3/4"	482	18,5	33	–	–
DN 80	430	219	485	205	3/4"	532	25	39	–	–
DN 100	500	273	533	262	3/4"	593	35,4	58,5	–	–
DN 125	590	324	627	302	1"	693	50	83	–	–
DN 150	625	356	727	317	1"	773	75	155	–	–
DN 200	760	406	972	390	1"	1030	147	359	–	–

* For certified values, consult manufacturer; ** Supplied with PN 100 flanges.

*** As standard, in separators manufactured with EN 1092-1 flanges, the drain connection is female threaded ISO 7 Rp. In models with ASME B16.5 flanges or SW connections, this connection is female threaded NPT. Alternatively, EN 1092-1 or ASME B16.5 flanged drain connections can be supplied (ASME in the same class as main connections).

Remarks: The top of the separator is supplied with a threaded connection which size does not exceed the size of the drain connection. This connection is always supplied with a threaded socket. It can be used for air venting or sensing pipe connection.

MATERIALS

DESIGNATION	MATERIAL
Body	P235GH / 1.0305
Head	P265GH / 1.0425
Inlet / Outlet pipe	P235GH / 1.0305
EN flange	P250GH / 1.0460
ASME flange	ASTM A105 / 1.0432
Socket	ASTM A105 / 1.0432
Internals	S235JR / 1.0038

FLANGE CONNECTIONS

RATING	SIZE	EN STANDARD	ASME STANDARD
PN 63	DN 15 to 40	EN 1092-1 PN 100	ASME B16.5 Class 600
PN 63	DN 50 to 200	EN 1092-1 PN 63	ASME B16.5 Class 600